

of methods by which the dependence of effective area upon pressure may be determined with considerable accuracy. The present paper deals in detail with two independent methods, termed the "similarity" and "flow" methods, recently developed at the National Physical Laboratory for this purpose.

Several early attempts to measure these distortion effects by the use of high pressure mercury manometers of various forms led to very inconsistent conclusions as to the order of magnitude of the effects to be expected (HOLBORN & SCHULZE 1915; CROMMELIN & SMID 1915; KEYES & DEWEY 1927; MEYERS & JESSUP 1931; BEATTIE & EDEL 1931). MICHELS (1923, 1924, 1932) has discussed applications to the differential type of piston-cylinder assembly. The most recent, and by far the most comprehensive, investigation of this kind is that of NEWITT and his colleagues, using a 9-m pressurised differential mercury manometer installed at the Imperial College of Science and Technology (BETT, HAYES & NEWITT 1954; BETT & NEWITT 1963). The measurements, covering a range up to 700 bars*, were difficult, and the resulting distortion factors for six pressure balance assemblies of similar design varied among themselves by much more than would be expected from their construction. It seems that more extensive data will be necessary before a final assessment of the high pressure mercury column can be made. ROEBUCK & CRAM (1937) and ROEBUCK & IBSER (1954) have dealt with a recent development of the multiple-column type of mercury manometer covering the range up to about 200 bars.

The distortion errors of the "controlled-clearance" type of pressure balance used at the National Bureau of Standards, Washington, have been considered by JOHNSON & NEWHALL (1953) and by JOHNSON, CROSS, HILL & BOWMAN (1957); (see also BENNETT & VODAR 1963). It is hoped that the results of direct comparisons between the methods of calibration developed at the NBS and the NPL may be available in the near future. Accounts of the distortion errors of various designs of piston-cylinder assemblies from the point of view of elastic theory have also been published by ZHOKOVSKI (1960), SAMOILOV (1960), EBERT (1935, 1949, 1951) and TOYOSAWA (1963, 1964). These authors, however, give primary attention to the establishment of the distortion factors by calculation rather than by experiment. The present paper, on the other hand, describes direct experimental methods which are independent of other pressure standards, and practically independent of detailed elastic theory, to which appeal is made only in the calculation of small correction terms.

2. Formal Theoretical Basis

a) General

As a basis for discussion of the methods described in this paper it is useful to develop a number of formal expressions for the changes of effective area of a piston-cylinder assembly consequent on the distortion due to the applied pressure. Initially, these formulae will not involve any assumption as to the form of distortion; later, however, the results of introducing certain simplifying assumptions will be examined. Unless otherwise stated, it is assumed only that the piston and cylinder are initially straight and coaxial, that there is circular symmetry in all planes perpendicular to the axis, and that the pressure transmitting fluid in the interspace flows in accordance with the normal laws of viscosity.

The essential features of the system are shown diagrammatically in Fig. 1. The upward force due to the fluid pressure P applied to the base of the piston, corrected for the forces due to the pressure and movement of the fluid in the gap between the piston and cylinder, is balanced by the total downward force due to the load, W . We denote by r and R the radii of the undistorted piston and cylinder respectively, $u(x)$ and $U(x)$ the increases in these radii for a total applied pressure P , $p(x)$ the pressure in the interspace, and $2h(x)$ the radial separation, at the axial distance

x measured from the lower end of the piston, l the total length of engagement, A_p the effective area of the system at the applied pressure P , and write $R - r = 2H$, where all of H , h , u and U are very small compared with r . P and p are always to be interpreted as the amount by which the actual pressure in the system exceeds the ambient pressure — normally atmospheric — to which the balance is exposed, and the effective area as a factor of dimensions L^2 which, when multiplied into the total applied pressure, gives the total downward force provided by the load which

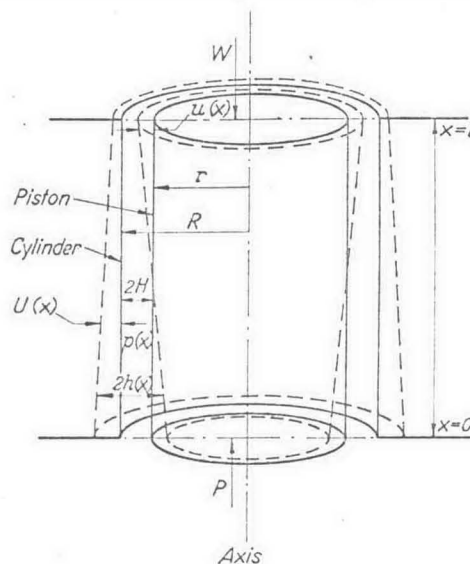

Fig. 1. Diagrammatic sketch of piston-cylinder assembly (clearance shown greatly exaggerated). — Undistorted boundaries of piston and cylinder, --- Distorted boundaries of piston and cylinder

is required to maintain the piston in equilibrium. For small applied pressures when distortion is negligible, we have from elementary considerations,

$$A_0 = \pi r^2 (1 + 2H/r) \quad (2.1)$$

neglecting second and higher-order terms in $2H/r$, where A_0 is the effective area at zero pressure.

To obtain the more general formulae when distortion is present we note that the fluid forces acting on the piston have the following components:

a) upward force due to applied pressure on base of piston

$$P\pi r^2 [1 + 2u(0)/r];$$

b) upward force due to fluid friction on flanks of piston

$$2\pi r \int_0^l \left(-h \frac{dp}{dx} \right) dx,$$

$$= 2\pi r \int_0^l \left[-\frac{d(ph)}{dx} + \frac{p}{2} \left(\frac{dU}{dx} - \frac{du}{dx} \right) \right] dx;$$

c) upward force due to vertical component of applied pressure on flanks of piston

$$2\pi r \int_0^l p \frac{du}{dx} \cdot dx.$$

Thus the total upward force acting on the piston is

$$P\pi r^2 [1 + 2u(0)/r] + 2\pi r \int_0^l \left[-\frac{d(ph)}{dx} + \frac{p}{2} \left(\frac{dU}{dx} + \frac{du}{dx} \right) \right] dx,$$

* 1 bar = 10^6 dyn/cm² = 10^5 N/m².